

# J.L. WINGERT CO.

## Specification Sheet FLAT BOTTOM HIGH CAPACITY FILTER FEEDERS MODEL FHC-[ ]HD

SS030011.D 08/17

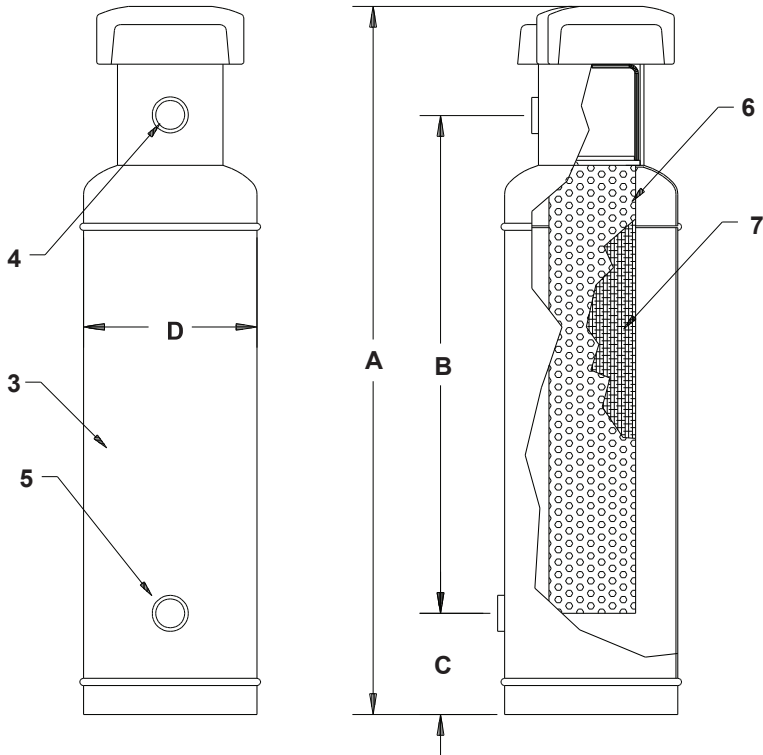
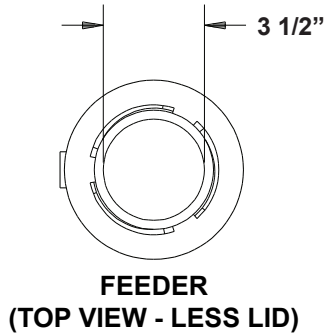
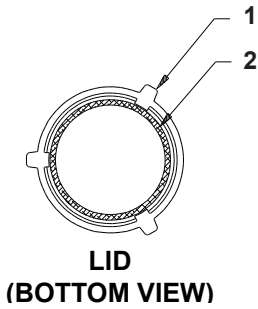

### SPECIFICATIONS

KEY	PART	DESCRIPTION
1	3071	<b>CLOSURE:</b> 3 1/2" cast iron, 1/4 turn closure, (O-ring included)
2	3072	<b>O-RING:</b> Buna-N O-ring 200 °F
3		<b>BODY:</b> Carbon steel
4		<b>INLET:</b> 3/4" FNPT
5		<b>OUTLET:</b> 3/4" FNPT
6	3160	<b>BASKET:</b> 304 stainless steel basket (3"D x 19"L)
7	3161	<b>FILTER:</b> 25 micron bag (3"D x 19"L) 93 in <sup>3</sup> capacity
<b>MAX. PRESSURE</b>		200 PSI (13.7 BAR)
<b>MAX. TEMPERATURE</b>		200 °F (93 °C)

### VOLUME (FILL CAPACITY)

MODEL	GALLONS	LITERS
<b>FHC-2HD</b>	2.59	9.79
<b>FHC-5HD</b>	6.83	25.85
<b>FHC-12HD</b>	12.85	48.64

### DIMENSIONS

KEY	FHC-2HD	FHC-5HD	FHC-12HD
<b>A</b>	27"	28 3/8"	44 5/8"
<b>B</b>	20"	20 5/8"	37 1/8"
<b>C</b>	3 1/2"	4 1/4"	4"
<b>D</b>	6"	10"	10"
<b>WEIGHT</b>	24 lbs. approx.	41 lbs. approx.	60 lbs. approx.
<b>SHIPPING DIMENSIONS</b>	6" x 6" x 28"	10" x 10" x 29"	10" x 10" x 46"

**Note: All dimensions are +/- 1/8". All weights are approximate. All dimensions are subject to change without notice.**

**MANUFACTURING:** Mixers, Bypass Feeders, Filter Feeders, Bromine Feeders, Sample Coolers, Sludge Traps, Separators, Separator Systems, Tank Stands, Tank Package Systems, Glycol Feed Systems, Coupon Racks, Control Stations, NEMA Enclosures, Custom Packaged Systems and Specialty Welding

P.O. Box 6207 | Garden Grove, CA 92846-6207 | 11800 Monarch St. | Garden Grove, CA 92841-2113 | Phone (714) 379-5519 | Fax (714) 379-5549  
Northern California Region | Phone (510) 487-5310 | Southwest Region | Phone (602) 470-1015 | Email: customerservice@jllwingert.com

[www.jllwingert.com](http://www.jllwingert.com)